

SPORTJET 520

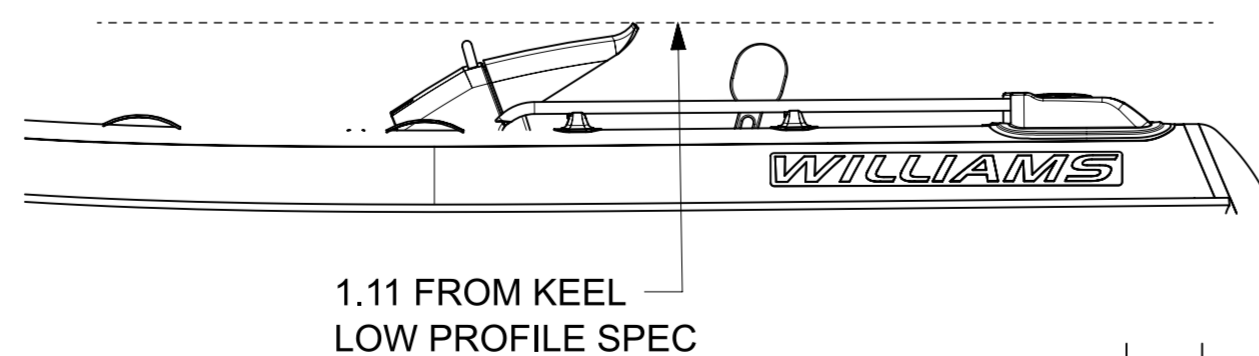
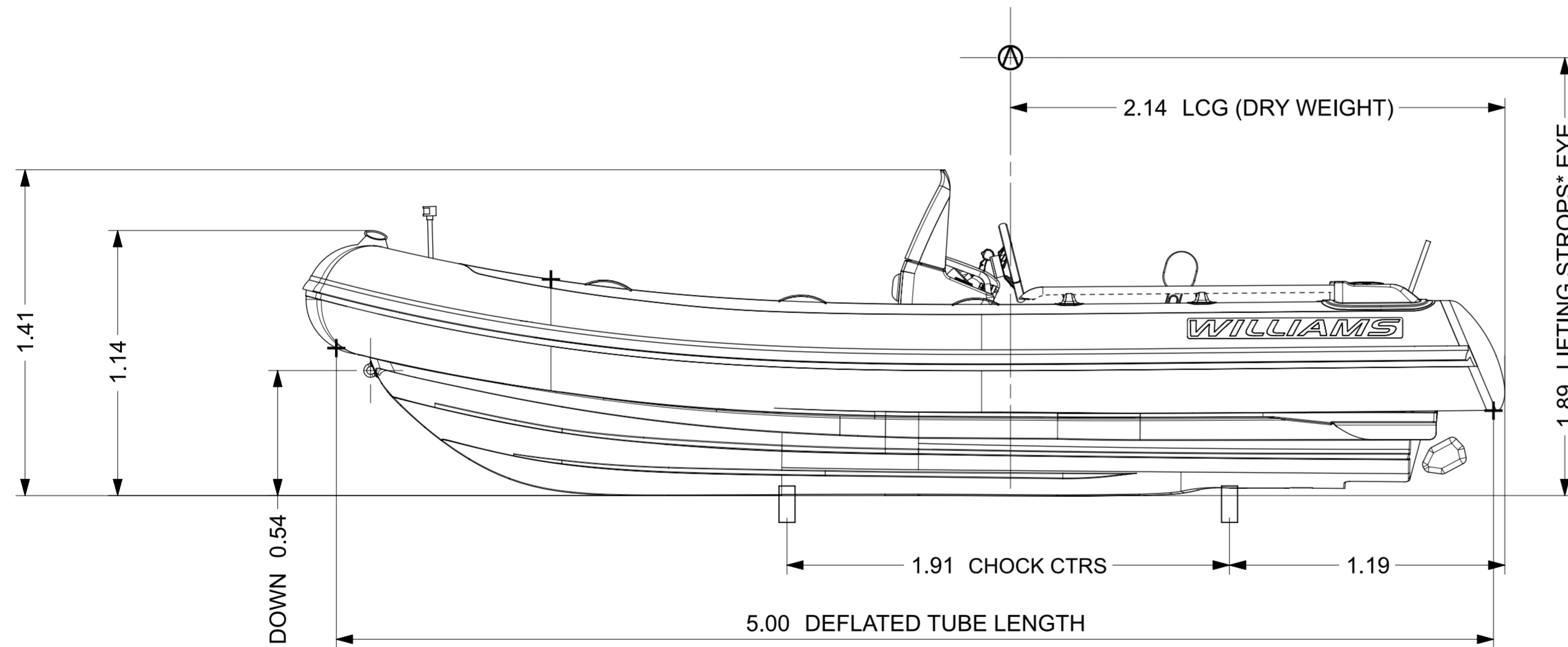
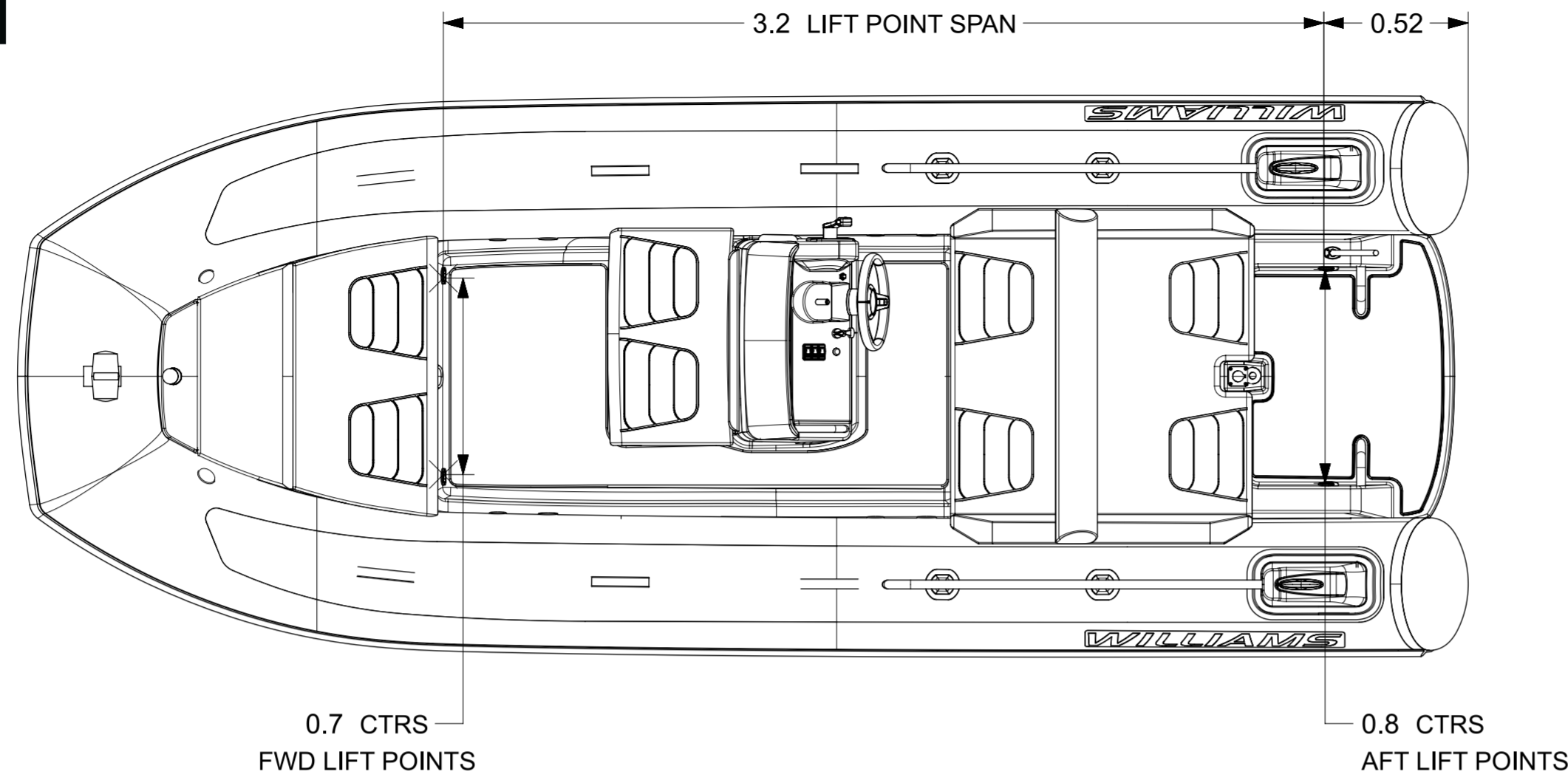

LOA	5.19m ±1%
BEAM OA	2.01m ±1%
DRAFT (FULLY LOADED)	0.42m
ENGINE	Rotax ACE 230
POWER	230hp ≅ 169.16 kW
DRY WEIGHT	680kg
SEATING CAPACITY	7
FUEL	PETROL
FUEL CAPACITY	100L
MAX. SPEED	52mph ≅ 84kph
No. TUBE COMPARTMENTS	5
CE DESIGN CATEGORY	C

NOTES:

- LENGTH / BEAM TOLERANCE DUE TO VARIATION IN TUBE PRESSURE.
- AVERAGE DRY WEIGHT STATED; ACTUAL WEIGHT DEPENDENT ON OPTIONS FITTED.
- LOW PROFILE:
 - DEFLATE TUBES (AUTO BOW TUBE INFLATOR OPTION REQUIRED*).
 - QUICK RELEASE STEERING WHEEL.
 - FULLY FOLD DOWN HELM.
- STANDARD CHOCKS*: 99-1460
CHOCK PROFILES DRAWING: RD472.

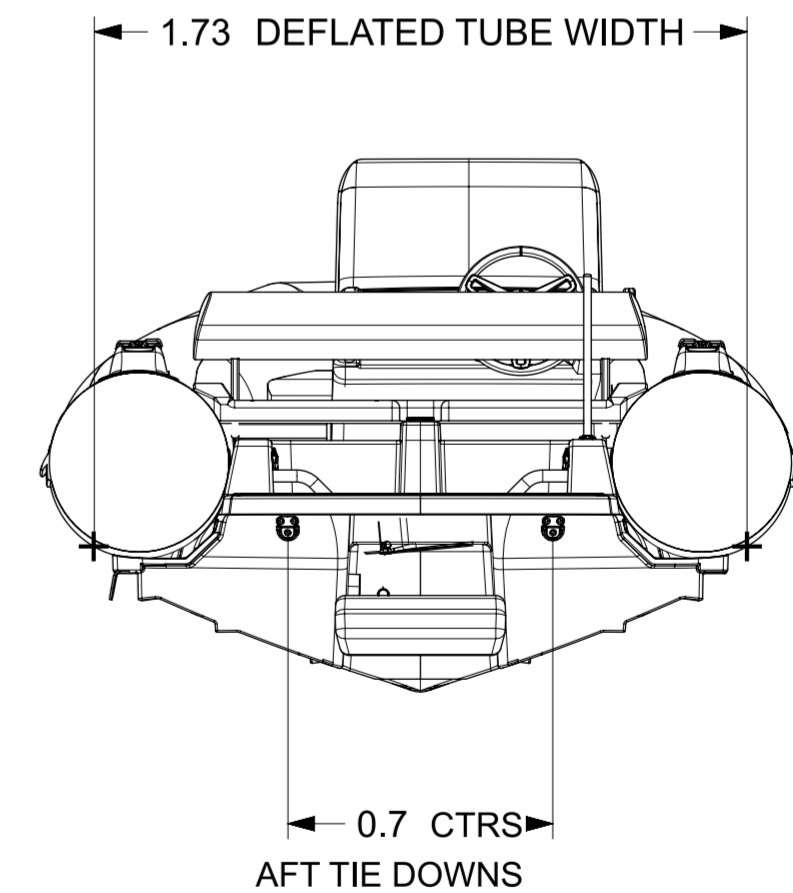

*OPTIONAL ACCESSORY

REV.	DATE	DETAILS	FWZ	DRAWN	APPVD
1	19/09/2023	PRODUCTION RELEASE			

GENERAL TOL.	0 ±0.50
	0.0 ±0.25
	0.00 ±0.10
	0° ±0.50°

DRAWN	FZ	19/09/2023
APPVD		
PROJECT	-	
INSPECTION LEVEL	-	
MATERIAL & FINISH	-	

WILLIAMS	
SPORTJET 520 (2024MY)	
PART NO.	WPT-000520SJ-2024MY-DATASHEET -dwg.1
SCALE	1:20
SHEET	1 OF 1

A2